

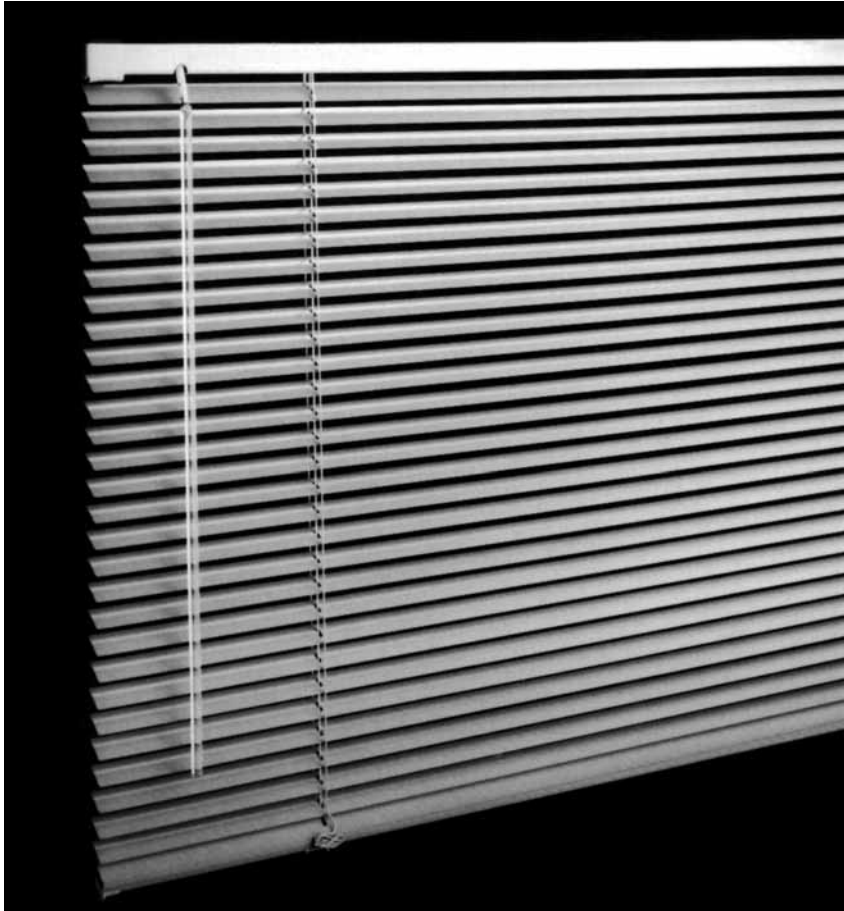

Riviera® Classic 1" Blind

Model #RIV1

Top quality 1" horizontal aluminum window covering for commercial applications.



KEY FEATURES:

- **DustGuard**
- **Headrail: 1" high x 1½" wide**
- **Nominal .008" slat thickness**
- **21.5mm ladder spacing**
- **Optional 19.5mm ladder spacing**
- **Guardian Tilter™ disengaging clutch mechanism**
- **Limited lifetime warranty**
- **90% recycled slat material**

PRODUCT OVERVIEW

The Riviera Classic 1" Blind represents Levolor's top quality horizontal blind backed by a limited lifetime warranty. Committed to both durability and aesthetics, the Riviera Classic 1" blind combines the highest quality components with visibly attractive features to provide an overall superior product.

The DustGuard feature is a permanent paint process that disrupts the natural static attraction of dust particles to the slat. By removing the primary reason blinds attract dust by 50-70 percent reduction in accumulation can be achieved. Less dust means less maintenance and a cleaner, more professional appearance.

The durable and sleek headrail is made of roll-formed corrosion-resistant Tomized® steel. The strength of the overall headrail profile provides smooth operation, even under heavy loads associated with large window applications. The steel hardware is machine-clinched, ensuring accurate alignment of moving parts and long, maintenance-free operation.

The nominal .008" thick slats are made of 5000 series magnesium aluminum alloy which includes 90% or higher recycled aluminum materials and provides overall strength and resiliency, guaranteeing a quality look for the life of the blind. As the industry leader, the Riviera Classic 1" blind's 21.5mm ladder spacing ensures tight closure and optimum light control. The exclusive Guardian Tilter disengaging clutch mechanism eliminates over rotation of the tilt wand and protects the tilt mechanism against breakage.

The Riviera Classic 1" blind is offered in a large selection of popular colors and specialty shapes. The SheerView perforation option provides a unique see-through feature, reducing solar heat gains by 42% as compared to a fully opened blind while optimizing the exterior view and maximizing light/glare control. Other options include the Top Lok® Cord Lock, which holds the blind completely up or down for a consistent look across all windows.

Riviera® Classic 1" Blind

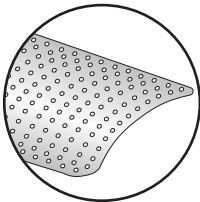
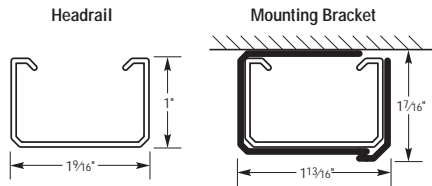
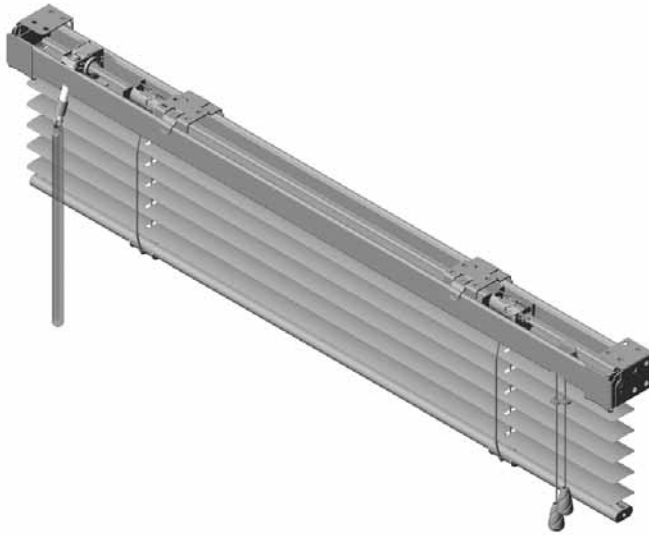

SheerView

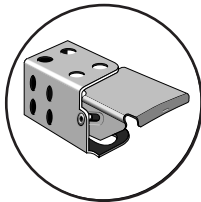

Open End Bracket



Hold-down Bracket

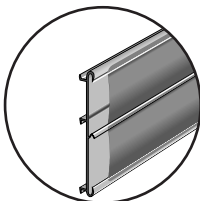

Vogue® Valance Option

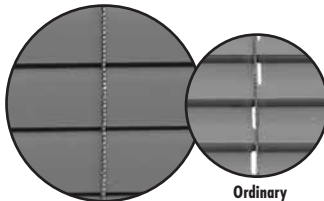

LightMaster® Route Hole

Ordinary Route Hole



PRODUCT SPECIFICATIONS

For more detailed specifications please reference Riviera 1" Blind product Guide Specifications.

Part II - Products

A. Riviera 1" Blind manufactured by Levolor.

B. Limited Lifetime Warranty

C. Materials:

- Headrail** shall be of .025" thick Tomized steel, "U" shaped, 1" high x 1 1/16" wide. All hardware shall be enclosed in the steel headrail.
- Guardian Tilter** mechanism shall be of .042" thick Tomized steel housing with a self-lubricating nylon, automatically disengaging worm and gear mechanism to eliminate overdrive.
- Cord Lock** shall be .042" thick Tomized steel and shall be crashproof.
- Drum and Cradle** shall be provided for each ladder.
 - a. Drums shall be of .031" thick Tomized steel.
 - b. Cradles shall be of .042" thick Tomized steel.
- Installation Brackets** shall be of at least .048" thick Tomized steel with a rivet-hinged safety locking front cover to permit removal of headrail without lateral movement.
- Ladders** (slat supports): Distance between slats shall not exceed 21.5mm. Optional 19.5mm ladder spacing.
- Slats** shall be of 5000 series magnesium aluminum alloy which includes 90% or higher recycled aluminum materials. Slats shall be nominally 1" wide and the thickness of the slats shall be nominally .008".

Coating includes DustGuard, a patented paint process which disrupts the natural static attraction of airborne dust particles, reducing dust build-up on the slat from 50-70%.

Slats shall be (select one):

- a. Unperforated.
 - b. SheerView – Slats shall be perforated with a staggered pattern of .020" diameter holes, nominally 177 per inch of slat length. Slats shall have an openness factor of 6%. Available on select colors. Not available with LightMaster™ option.
- Bottomrail** shall be of .023" thick Tomized steel.
 - Options** shall include:
 - a. Cutouts
 - b. Extension Brackets
 - c. Hold Down Brackets
 - d. LightMaster™ (model RIV1-P), 18mm Ladder Spacing
 - e. MultiColor Striping
 - f. Multiple Blinds on One Headrail
 - g. Pivot Plates
 - h. Projection Brackets
 - i. Ring Pull
 - j. Specialty Shapes
 - k. Telescopic or Non-Telescopic Pole
 - l. Top-Lok® Cord Lock
 - m. Universal Ring Tilter
 - n. 19.5mm Ladder Spacing
 - o. 2 Slat Framed Vogue® Valance

© Copyright 2007 Levolor. All rights reserved. US and non-US patents and patents pending. Product specifications are subject to change without notice. Printed in the USA.